

APOLLO rimini wave vertical tube on tube technical specification

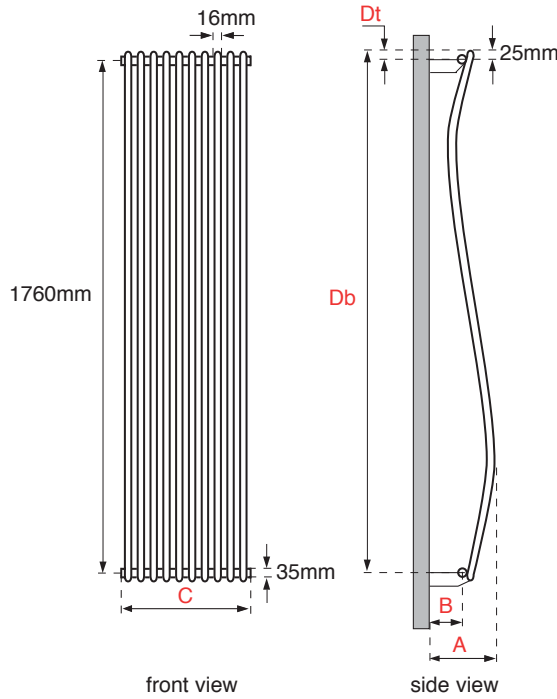

RIMINI VERTICAL TUBE ON TUBE DIMENSIONS (mm)			
MODEL HEIGHT			1810
Width of radiator			(No. tubes x 28 + 2)
Tube diameter			16
Collector diameter			35
Section width (tube + space)			28
Wall to front of rad		(A)	125
Wall to pipe centres	Side entry	(B)	55
	Bottom entry		N/A
Tapping centres	Side entry	(C)	Width
	Bottom entry		N/A
Pipe centres	Side entry		Width plus valves
	Bottom entry		N/A
Bracket positions	Top	(Dt)	25
	Bottom	(Db)	1785

RIMINI WAVE WHITE WEIGHTS AND VOLUMES (per radiator)			
Model width mm	300	400	500
Dry weight (A) Kg	8.60	12.10	15.50
Water content (B) Litres	3.10	4.40	5.60
Working weight (A+B) Kg	11.70	16.50	21.10
Outputs: Watts $\Delta T=50k$	614	860	1105

RIMINI WAVE CHROME WEIGHTS AND VOLUMES (per radiator)			
Model width mm	300	400	500
Dry weight (A) Kg	8.60	12.10	15.50
Water content (B) Litres	3.10	4.40	5.60
Working weight (A+B) Kg	11.70	16.50	21.10
Outputs: Watts $\Delta T=50k$	491	688	884

ADDITIONAL INFORMATION		
Material		E260 grade carbon steel
Steel tube diameter		16mm
Steel thickness	Collector	1.2mm
	Tubes	1.5mm
Maximum working pressure		7 bar/700 kPa
Testing pressure		No more than 9.1 bar
Maximum working temperature		85°C

TEMPERATURE			
FACTORS FOR DIFFERENCES BETWEEN MEAN WATER TEMPERATURE AND ROOM TEMPERATURE IN °C AND °F OTHER THAN 50 °C (90 °F)			
5 °C	0.050	10 °F	0.057
10 °C	0.123	20 °F	0.142
15 °C	0.209	30 °F	0.240
20 °C	0.304	40 °F	0.348
25 °C	0.406	50 °F	0.466
30 °C	0.515	60 °F	0.590
35 °C	0.629	70 °F	0.721
40 °C	0.748	80 °F	0.858
45 °C	0.872	90 °F	1.000
50 °C	1.000	100 °F	1.147
55 °C	1.132	110 °F	1.298
60 °C	1.267	120 °F	1.454
65 °C	1.406	130 °F	1.613
70 °C	1.549	140 °F	1.776
75 °C	1.694		

TO APPLY THE FACTORS SHOWN IN THE TABLE TO OUR QUOTED OUTPUTS. MULTIPLY THE QUOTED OUTPUT BY THE CHOSEN OPERATING FACTOR TO GIVE THE OUTPUT

The thermal outputs expressed at $\Delta T=50k$ comply with European regulation EN 442-2

APOLLO rimini wave horizontal tube on tube technical specification

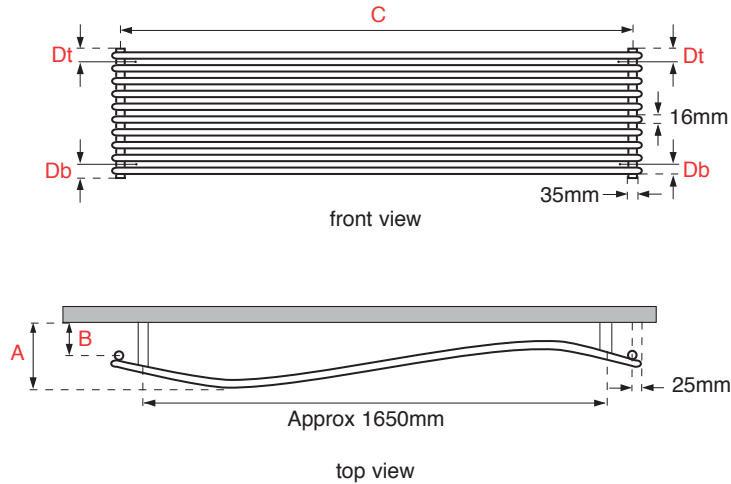

RIMINI HORIZONTAL TUBE ON TUBE DIMENSIONS (mm)			
MODEL WIDTH			1810
Height of radiator			(No. tubes x 28 + 2)
Tube diameter			16
Collector diameter			35
Section width (tube + space)			28
Wall to front of rad		(A)	90 - 110
Wall to pipe centres	Side entry		N/A
	Bottom entry	(B)	70
Tapping centres	Side entry		N/A
	Bottom entry	(C)	Width less 50
Pipe centres	Side entry		N/A
	Bottom entry		Width less 50
Bracket positions	Top	(Dt)	30
	Bottom	(Db)	30

RIMINI WAVE WHITE WEIGHTS AND VOLUMES (per radiator)			
Model height mm	300	400	500
Dry weight (A) Kg	8.60	12.10	15.50
Water content (B) Litres	3.10	4.40	5.60
Working weight (A+B) Kg	11.70	16.50	21.10
Outputs: Watts $\Delta T=50k$	614	860	1105

RIMINI WAVE CHROME WEIGHTS AND VOLUMES (per radiator)			
Model height mm	300	400	500
Dry weight (A) Kg	8.60	12.10	15.50
Water content (B) Litres	3.10	4.40	5.60
Working weight (A+B) Kg	11.70	16.50	21.10
Outputs: Watts $\Delta T=50k$	491	688	884

ADDITIONAL INFORMATION		
Material		E260 grade carbon steel
Steel tube diameter		16mm
Steel thickness	Collector	1.2mm
	Tubes	1.5mm
Maximum working pressure		7 bar/700 kPa
Testing pressure		No more than 9.1 bar
Maximum working temperature		85°C

TEMPERATURE			
FACTORS FOR DIFFERENCES BETWEEN MEAN WATER TEMPERATURE AND ROOM TEMPERATURE IN °C AND °F OTHER THAN 50 °C (90 °F)			
5 °C	0.050	10 °F	0.057
10 °C	0.123	20 °F	0.142
15 °C	0.209	30 °F	0.240
20 °C	0.304	40 °F	0.348
25 °C	0.406	50 °F	0.466
30 °C	0.515	60 °F	0.590
35 °C	0.629	70 °F	0.721
40 °C	0.748	80 °F	0.858
45 °C	0.872	90 °F	1.000
50 °C	1.000	100 °F	1.147
55 °C	1.132	110 °F	1.298
60 °C	1.267	120 °F	1.454
65 °C	1.406	130 °F	1.613
70 °C	1.549	140 °F	1.776
75 °C	1.694		

TO APPLY THE FACTORS SHOWN IN THE TABLE TO OUR QUOTED OUTPUTS. MULTIPLY THE QUOTED OUTPUT BY THE CHOSEN OPERATING FACTOR TO GIVE THE OUTPUT

The thermal outputs expressed at $\Delta T=50k$ comply with European regulation EN 442-2